

OPERATOR'S MANUAL PTO DRIVEN VACUUM COLLECTOR

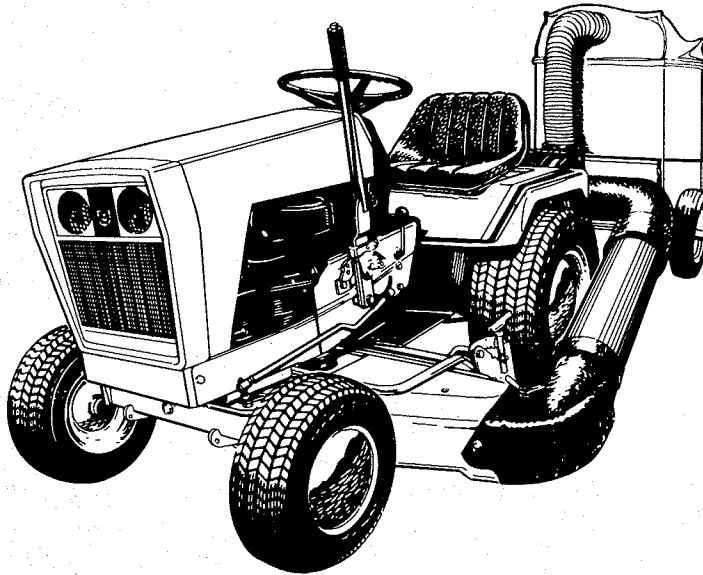

VACUUM COLLECTOR (PTO)
MFG. NO. 1690503

VACUUM COLLECTOR (PTO)
MFG. NO. 1690024

42 INCH MOWER ADAPTOR
MFG. NO. 1690027

48 INCH MOWER ADAPTOR
MFG. NO. 1690026

Identification

When ordering replacement parts for your vacuum collector, be prepared to give your dealer the identification number found on the identification plate.

Refer to ID no. when
writing or ordering parts.

ID NO.

VACUUM COLLECTOR IDENTIFICATION PLATE

Accessories

See your dealer to purchase any of the following accessories for your tractor or vacuum collector.

REQUIRED ACCESSORIES

42" & 48" Mower Adaptors
Dump Cart (6.5 cu. ft. capacity)
Dump Cart Cover
Front Wheel Weights (required for slopes over 20
percent (11.3 degrees))

OPTIONAL ACCESSORIES

Roving Nozzle - Collects grass, leaves in out of the way places.
Wheel Weights - (Required on slopes) Increases tractor steering ability and stability.
Hour Meter - Records tractor operating time in tenths of an hour.

Models illustrated in this manual may vary slightly from the model you have.

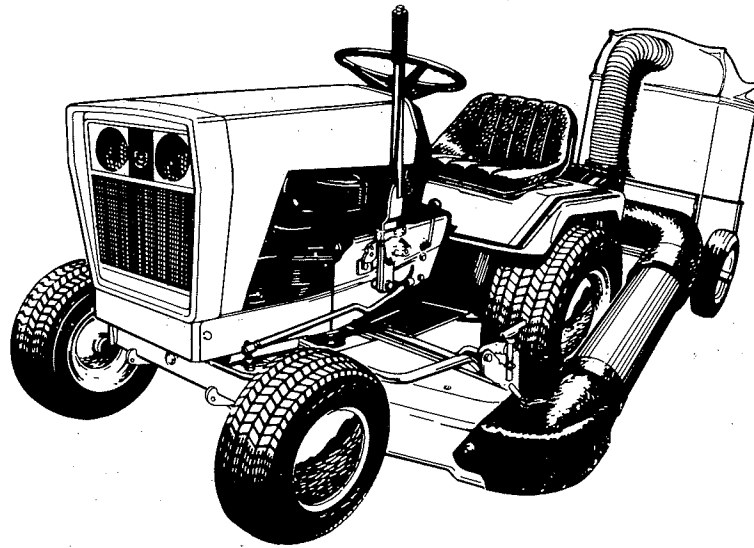



Contents

IDENTIFICATION	Inside Front Cover
ACCESSORIES	Inside Front Cover
SAFETY RULES	2
DECALS	3
OPERATION	4
CONTENT OF SECTION	4
INSTALLING VACUUM COLLECTOR ON TRACTOR	4
CHECKS BEFORE STARTING	5
OPERATING THE VACUUM COLLECTOR	5
REMOVING THE VACUUM COLLECTOR FROM TRACTOR	6
NORMAL CARE	7
CONTENT OF SECTION	7
SCHEDULED CARE	7
STORAGE	7
TROUBLESHOOTING	9
CONTENT OF SECTION	9
TROUBLESHOOTING PROCEDURES	9
BELT ADJUSTMENT	10
ASSEMBLY	11
CONTENT OF SECTION	11
ASSEMBLY OF VACUUM COLLECTOR	11
SPECIFICATIONS	12

Safety Rules



Read these safety rules and follow them closely. Failure to obey these rules could result in loss of control of vehicle, severe personal injury to yourself or bystanders, or damage to property or equipment. The triangle  in the text signifies important cautions or warnings which must be followed.

 ALL WARNING, CAUTION, and instructional messages on this attachment and on your tractor should be carefully read and obeyed. Personal bodily injury can result when these instructions are not followed.

GENERAL

- Read this manual and tractor Operators Manual carefully. Be thoroughly familiar with the controls and the proper use of the equipment.
- Never allow children to operate the machine. Do not allow adults to operate it without proper instruction.
- Do not carry passengers.
- Use only attachments or accessories designed for your machine. See your dealer for a complete list of recommended attachments or accessories.
- Keep the area of operation clear of all persons, particularly small children, and pets.
- When using any attachments, never direct discharge of material toward bystanders nor allow anyone near the vehicle while in operation.
- Make sure:
 - a. tractor and attachments are in good operating condition,
 - b. all safety devices and shields are in good working condition, and
 - c. all adjustments (cutting height, etc.) have been made.

PREPARATION

- Make sure entire unit is installed. Never operate vacuum collector with any part detached except with roving nozzle installed and mower disengaged.
- Handle gasoline with care - it is highly flammable.
 - a. Use approved gasoline container.
 - b. Never remove the cap of the fuel tank or add gasoline to a running or hot engine, or fill the fuel tank indoors. Wipe up spilled gasoline.

- Do not run tractor engine indoors. Exhaust fumes are deadly.
- Clear the work area of objects which might be picked up and thrown.
- Disengage all attachment clutches and shift into neutral before attempting to start the engine.
- Wear heavy footwear. Do not operate tractor when barefoot or when wearing open sandals or canvas shoes.

OPERATION

- Disengage power to attachment(s) and stop the engine before leaving the operator's position.
- Disengage power to attachment(s) and stop the engine before making any repairs or adjustments.
- Stop tractor engine and remove key before unclogging hoses or emptying dump cart.
- Stay alert for holes in the terrain and other hidden hazards. Be extra careful when operating on wet or slippery surfaces.
- The vehicle and attachments should be stopped and inspected for damage after striking a foreign object, and the damage should be repaired before restarting and operating the equipment.
- Disengage power to mower and vacuum collector when transporting or not in use.
- When mowing, proceed as follows:
 - a. Mow only in daylight or in good artificial light.
 - b. Never operate the tractor without the mower clutch safety interlock switch properly attached and working.
 - c. Check the blade mounting bolts for proper tightness at frequent intervals.
- Do not stop or start suddenly when going uphill or downhill. Mow up and down the face of steep slopes - never across the face.
- Reduce speed on slopes and in sharp turns to prevent tipping or loss of control. Use extreme caution when changing direction on slopes.

- Watch out for traffic - when crossing or near roadways.
- If equipment begins to vibrate abnormally, disengage power to attachments and stop the engine at once. Inspect for damage and correct before restarting tractor.
- Be especially careful not to touch tractor or attachment parts which might be hot from operation. Allow such parts to cool before attempting to maintain, adjust or service.
- Use counterweight(s) or wheel weights when suggested in the Operator's Manual.
- Take all possible precautions when leaving the vehicle unattended, such as disengaging the power-take-off, lowering the attachment(s), shifting into neutral, setting the parking brake, stopping the tractor engine and removing the key.

- Keep the vehicle and attachments in good operating condition and keep safety devices in place.

MAINTENANCE & STORAGE

- Keep all nuts, bolts and screws tight to be sure the equipment is in safe working condition.
- Do not change the engine governor settings or overspeed engine.
- To reduce fire hazard, keep the engine free of grass, leaves or excessive grease.
- Never store the equipment with gasoline in the tank inside a building where fumes may reach an open flame or spark. Allow the engine to cool before storing in any enclosure.

Decals

ALL WARNINGS, CAUTION and instructional messages on this unit and on your tractor and mower should be carefully read and obeyed. Personal bodily injury can result when these instructions are not followed. The information is for your safety, and it is important.

The smaller decal is on your vacuum collector. The larger decal will be on your vacuum collector if a roving nozzle has been installed.

CAUTION
FOR YOUR SAFETY
DO NOT OPERATE THIS VACUUM COLLECTOR WITH ANY PART OF THE COLLECTOR DETACHED. BE SURE TO DISENGAGE TRACTOR MOWER WHEN USING THE ROVING NOZZLE.

LOCATION: AT TOP OF BLOWER HOUSING



WARNING

FOR YOUR SAFETY

Do not operate the vacuum collector with any part detached except with roving nozzle installed and mower disengaged.

To disengage mower use the following procedure.

1. With engine and all motion stopped, reach behind left rear tire and push the belt tensioning lever down and forward.
2. Raise the seat deck. Use a board or other object to support the seat deck so it cannot fall forward.
3. Grasp the belt behind the rear idler pulley and slip it off the pulley. Position the belt in front of the pulley and place in pulley groove. Pull the belt tensioning lever back and up.
4. The two belt sections must be trapped between the two idler pulleys as shown. The belt must form a loop around the PTO pulley so belt is not tight in PTO pulley groove.
5. Lower the seat deck before starting the engine.

NOTE: Refer to roving nozzle operator's manual for more information.

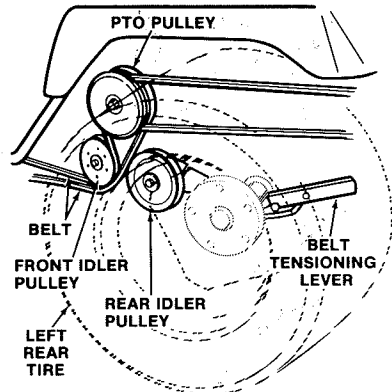

Operation

CONTENT OF SECTION

This section provides operating procedures for the vacuum collector. Included are procedures for installing the vacuum collector on the tractor and removing the vacuum collector, as well as lawn cleaning hints.

INSTALLING VACUUM COLLECTOR

To install the vacuum collector on your tractor, proceed as follows:

1. If installing for the first time, make sure the vacuum collector has been properly assembled as described in Assembly section at back of this manual.
2. Lift the blower assembly up and hook the upper hitch arms over the support shaft while inserting lower hitch arms in drawbar. Align the lower hitch arms with the holes in the drawbar and insert the two pins. It may be necessary to lift up on blower. Install the spring clips in the pins.

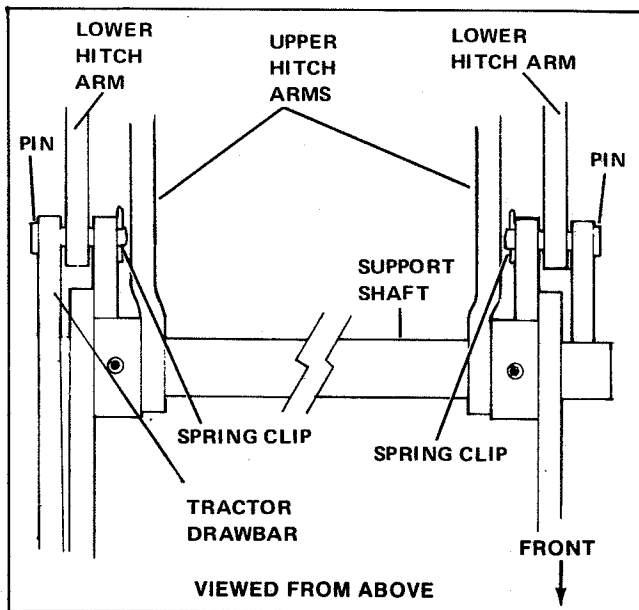

Figure 1. Attaching Blower Unit to Tractor

3. Remove the shield (A, figure 5) by removing the three wing screws (if installed).
4. Install the vacuum collector drive belt in the outer groove on the tractor PTO pulley. Place the other end of the belt on the blower drive pulley, with the idler pulley positioned underneath the lower portion of the belt, as shown in figure 2. Be sure the idler spring is hooked over the left upper hitch arm.

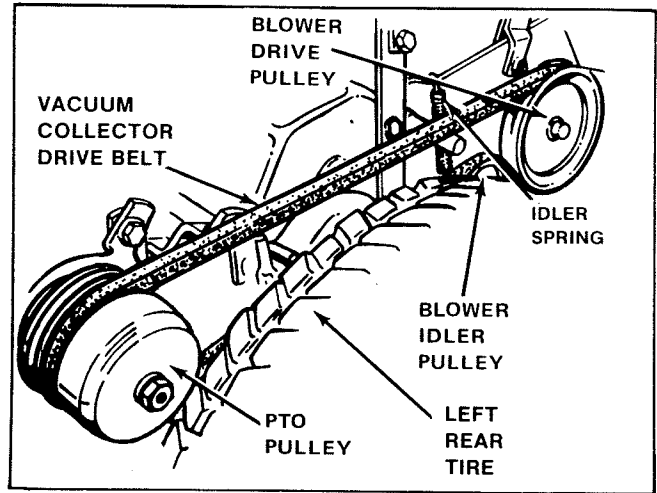

Figure 2. Drive Belt

5. Install the pulley shield (A, figure 5) to left side as shown in figure 5 with the three wing screws. (The three shield brackets are shown in figure 13).
6. Remove the deflector from the mower and install the correct vacuum collector adaptor to the mower housing, and tighten the wing nut. (See the Assembly section of this manual on how to prepare mower housing to install adaptor.)
7. Slide the inlet tube over the vacuum collector adaptor end, and slide the other end of the inlet tube into the short side of the inlet elbow. (See figure 3.)
8. Slide the inlet flange (on the long side of the inlet elbow) into the retaining clips on the blower housing. Slide the two clamp bars over the flange and tighten the clamp bars with the two wing nuts (see figure 3).

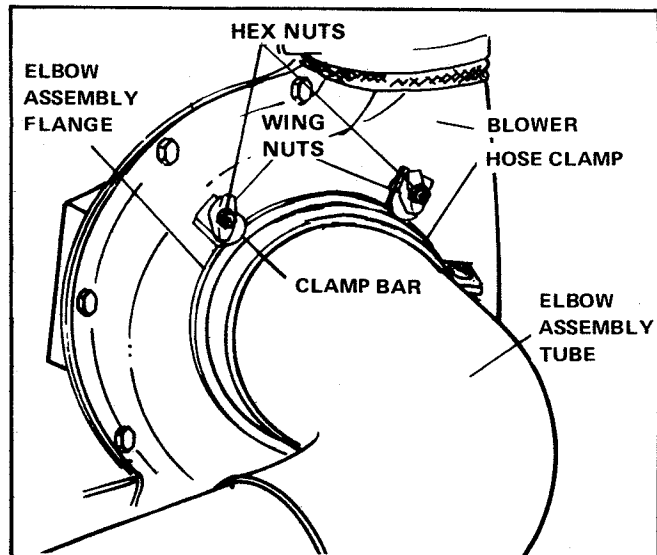

Figure 3. Installing Inlet Tubes

9. Place the discharge hose over the blower deflector and attach it to the blower housing with a hose clamp. Hose will be tight and the best method of installation is to use a twisting action. Tighten screw. (See figure 4.)

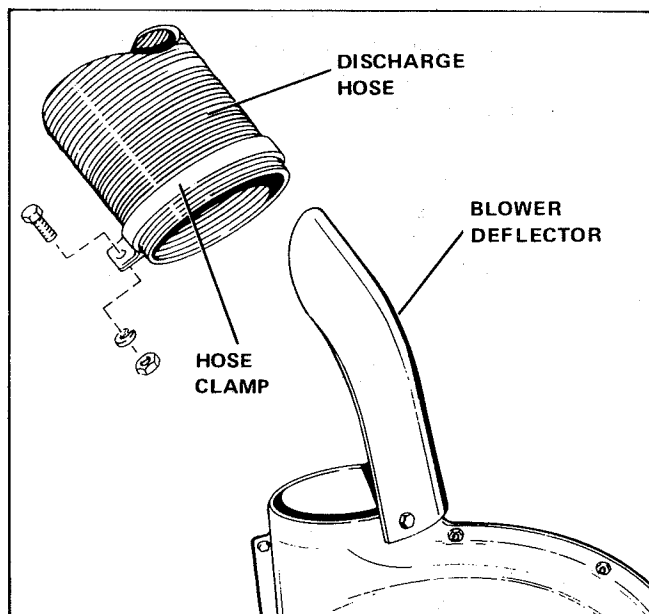

Figure 4. Discharge Hose Installation

10. Attach the dump cart, with the dump cart cover installed, to the drawbar on the vacuum collector assembly.
11. If the discharge hose measures 54 inches it must be reduced to 40 inches by cutting with a hacksaw. (If an early model dump cart which does not have side extensions is used, it will not be necessary to cut the hose.) Dull the ends of the steel reinforcement wires with a file.
12. Attach the hose connector to the hose and secure with the clamp. (The connector and clamp are supplied with the dump cart.) Tighten the clamp securely on front edge of connector.
13. Connect the hose connector to the dump cart connector by snapping into place.
14. Refer to instructions supplied with dump cart and side extensions for more information on those products.

CHECKS BEFORE STARTING

The checks listed below should be performed before each use of the vacuum collector.

1. Be sure you are familiar with the safety precautions controls and operation of the tractor. Read the tractor Operating Manual very carefully.
2. Check the mower and vacuum collector to be sure they are properly installed and to be sure that all nuts, bolts and pins are securely fastened.

WARNING

Do not operate the vacuum collector with any part detached except with roving nozzle installed and mower disengaged. For roving nozzle operation, see roving nozzle Operator's Manual.

3. Refer to the Normal Care section of this manual to determine and perform any needed care of the vacuum collector.
4. Clear the lawn of all sticks, stones, wire and other debris which may be caught or thrown by the mower blades and vacuum blower.

OPERATING THE VACUUM COLLECTOR

WARNING

Do not work around the mower housing or blower area until you are certain that the mower blades and the blower fan have stopped rotating.

Always stop the tractor engine and disengage the PTO before removing any of the hoses or attempting to clean out any part of the vacuum collector.

Before operating the vacuum collector, be sure you are thoroughly familiar with the operation of your tractor. Consult your tractor's Operator's Manual if you have any questions on its operations.

Under average dry conditions set the tractor engine throttle about 3/4 open and operate mower at normal ground speeds. Under damp conditions or when collecting thick heavy material run engine at full throttle and use slow ground speed.

When collecting leaves and tall grass, raise the mower to highest cutting height on first pass, the lower it for the second pass.

In extremely heavy or tall green grass it may be necessary to cut only half the width of the mower to prevent the hoses from clogging up. Check the hoses and blower housing periodically to make sure the material does not accumulate and block the flow to cart.

NOTE

It is recommended that you do not try to collect grass or leaves that are wet with external moisture such as rain or dew.

Best results for filling the covered cart can be obtained with at least a 3/4 or more engine speed throttle setting.

Dumping Cart

To empty the cart, back it into the area where material is to be dumped, disengage the drive to the mower and to the fan. Shift tractor transmission into neutral, apply the parking brake and stop the tractor engine.

Unhook the latch in front of dump cart. The hose is attached to a connector which snaps into place. Disconnect the hose. Remove the upper and lower tail gates. The dump cart can be tipped back so it rests on its rear side. More detailed information about the dump cart and cover is in the instructions supplied with those products.

Operation On Slopes

WARNING

Never operate on slopes greater than 35 percent (19.3°) which is a rise of 3-1/2 feet (1066 mm) vertically in 10 feet (3.1 m) horizontally. When operating on slopes greater than 20 percent (11.3°) front wheel weights are required. Select slow ground speed before driving onto a slope. Avoid using brakes to control speed. Drive up and down the face of slopes, and never across the face. Use caution when changing directions and **DO NOT STOP OR START.**

5. Remove adaptor from mower housing by removing wing nut from the top carriage bolt.
6. Replace deflector on mower housing, holding it in place with the wing nut used to hold the adaptor, and the hardware in the rear hole removed from the mower housing when the deflector was removed. (See figure 6.)

WARNING

Do not operate mower without deflector or entire vacuum collector system installed. The vacuum collector adaptor must be used with the vacuum collector, and should not be used by itself in place of the mower deflector.

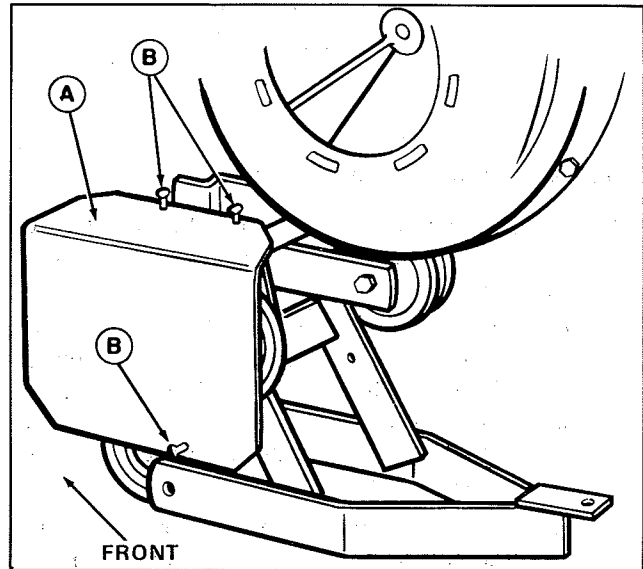

Figure 5. Shield Installed Left-Hand Side

- A. Shield B. Wing Screws.

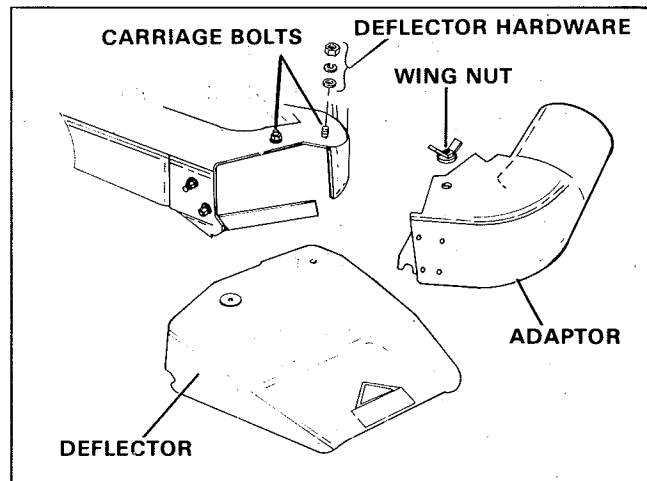

Figure 6. Replacing Mower Deflector

REMOVING THE VACUUM COLLECTOR

When desired, remove the vacuum collector as follows:

1. Remove discharge hose from cart cover and dump cart from vacuum collector drawbar.
2. Remove inlet elbow and inlet tube from blower assembly and adaptor.
3. Remove vacuum collector drive belt from tractor PTO pulley. To loosen tension on the belt, it can be slipped off the idler pulley. If necessary, remove the shield (A, figure 5) for clearance. Reinstall the shield and three wing screws to avoid loss.
4. Remove pins from drawbar and lift blower assembly from tractor. Replace pins and spring clips in vacuum collector hitch for storage.

Normal Care

CONTENT OF SECTION

Your vacuum collector was designed and built to provide years of service with only minor care. Certain tasks, however, must be performed to keep it in good operating condition and to avoid costly repairs. This section describes and provides procedures for the necessary care of the vacuum collector.

SCHEDULED CARE

A schedule for routine care of the vacuum collector is provided in figure 7. Some of the schedule requirements are based on operating hours. For this reason, it will be necessary to determine or estimate total operating time. This is easily accomplished if your tractor is equipped with an hour meter. If not, you can determine normal times for regular jobs. Multiply these normal times by the number of times you perform these jobs and add any unusual operating time to estimate the total operating time.

STORAGE

To protect you vacuum collector, store it in an enclosed dry area. To prepare it for off-season storage, perform the following:

1. Remove unit from tractor. (Refer to procedures in Operation section.)
2. Clean vacuum collector to remove all grass and dirt.
3. Coat all bare metal surfaces with paint or a light coat of oil to prevent rusting.
4. Lubricate the vacuum collector cross shaft. (See figure 9.)

Care Required	See Figure	Before Each Use	After Each Use	Every 10 Hours	Yearly
Check to be sure all screws, nuts, bolts, and pins are present and secure.	None	•			
Clean vacuum collector, hoses, cart and cover of all grass and dirt.	8		•		
Lubricate blower cross shaft	9			•	
Lubricate dump cart	9				•*
* More often under heavy use.					

Figure 7. Summary of Scheduled Care

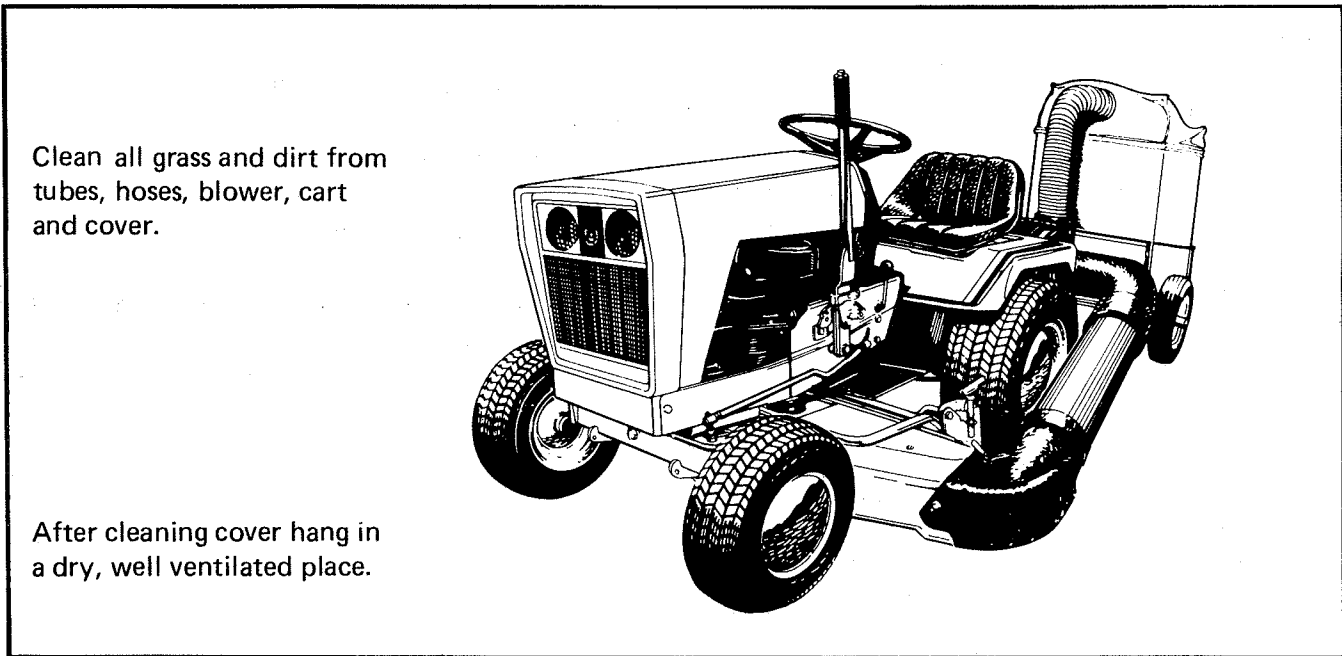

Figure 8. Clean Vacuum Collector, Cart & Cover

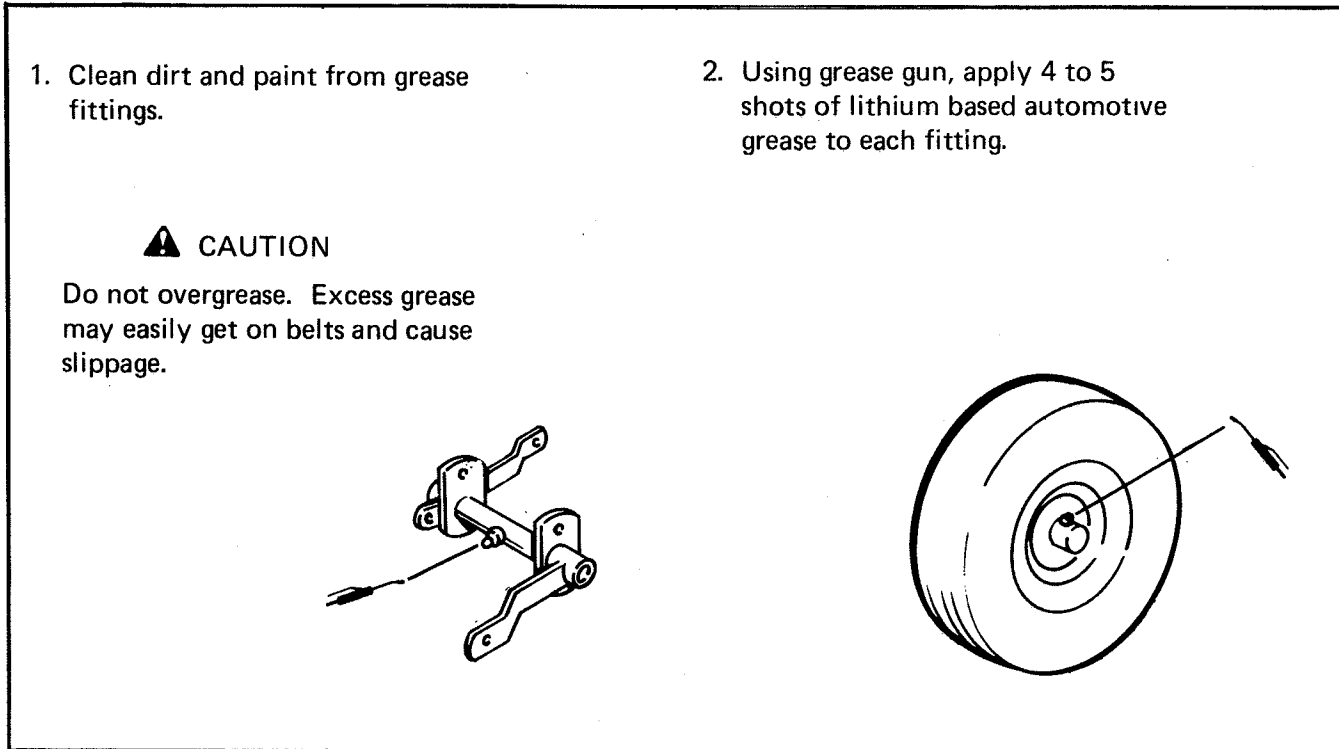

Figure 9. Lubrication of Cross Shaft & Dump Cart

Troubleshooting

CONTENT OF SECTION

This section provides troubleshooting and repair instructions for the more common and easily corrected problems.



WARNING

To avoid serious injury, perform maintenance on the vacuum collector only after stopping the tractor engine and waiting for all moving parts to come to a complete stop. Always remove the ignition key before beginning the maintenance to prevent accidental starting of the engine.

TROUBLESHOOTING PROCEDURES

Troubleshooting procedures are provided in figure 10. To use these procedures, first locate the problem description that best describes the trouble that you have encountered. Check the possible causes one at a time in the order that they are listed. Correct any problems that are found and operate the vacuum collector again to verify that you have eliminated the trouble.

Problem	Cause
<p>1. Leaves and grass not being completely picked up.</p>	<p>A. Engine speed too slow. Run at 3/4 to full throttle.</p> <p>B. Ground speed too fast. Use lower gear.</p> <p>C. Hose connections loose. Check and tighten any loose connections.</p> <p>D. Belts worn or dirty. Check and clean or replace as needed. Check belt adjustment.</p> <p>E. Twig lodged in mower adaptor. Clear the adaptor then reinstall.</p>
<p>2. Hoses plug easily.</p>	<p>A. Grass or leaves too wet. Wait for drier conditions.</p> <p>B. Grass too high. Reduce tractor ground speed, reduce cutting width, or raise mower adjustment for the first pass, lower it for the second pass.</p>
<p>3. Vacuum collector blower vibrates abnormally.</p>	<p>A. Dirt built up on blower fan blades. Clean and try again.</p> <p>B. Fan or shaft bent or broken. Repair as necessary.</p> <p>C. Shaft bearings worn. Repair as necessary.</p>

Figure 10. Troubleshooting Chart

BELT ADJUSTMENT

NOTE

Early model vacuum collectors do not have the eccentric washer (A, figure 11) which makes belt adjustment possible.

To gain access for adjustment, remove the shield (A, figure 5) by removing the three wing screws. Be sure to reinstall the shield after completing the adjustment.

Measure the distance between the belt strands at point shown in figure 12. If the measurement is between 1-3/4 inch and 2-1/4 inch, the adjustment is OK. If not, adjust the belt as follows.

To increase the measurement, rotate the eccentric washer (A) and cross shaft forward, then tighten the nut (C). Recheck the measurement and readjust if necessary. If adjustment is correct, tighten the two cross shaft screws (D, figure 11).

To decrease the measurement, rotate the eccentric washer (A) and cross shaft forward, then tighten the nut (C). Recheck the measurement and readjust if necessary. If adjustment is correct, tighten the two cross shaft screws.

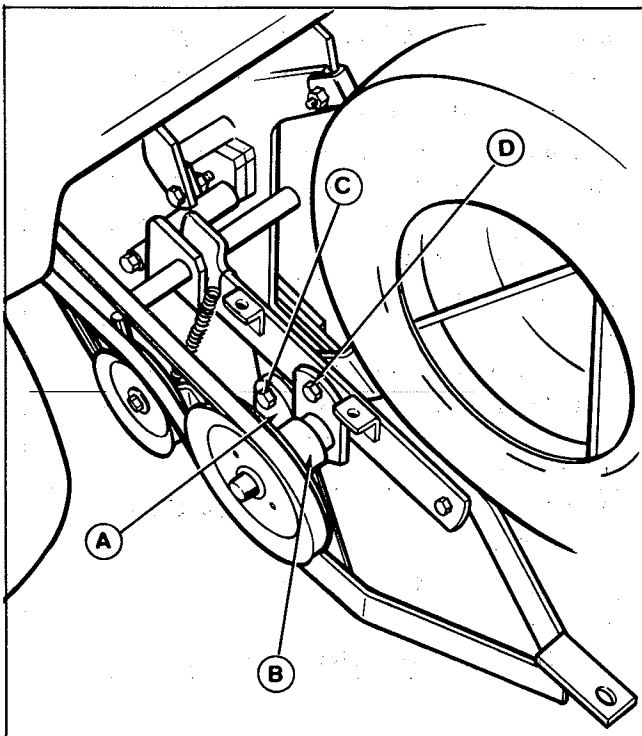

Figure 11. Belt Adjustment

- A. Eccentric Washer
- B. Cross Shaft
- C. Nut
- D. Screw

To increase the measurement, use a crowbar as a lever (figure 13) to rotate cross shaft toward rear. While holding the cross shaft in position, rotate the washer (A) until it meets the cross shaft then tighten the nut (C). Recheck the measurement and readjust if necessary.

When adjustment is correct, tighten the two cross shaft screws (D, figure 11). Reinstall the shield (A, figure 5). The shield brackets are shown in figure 13.

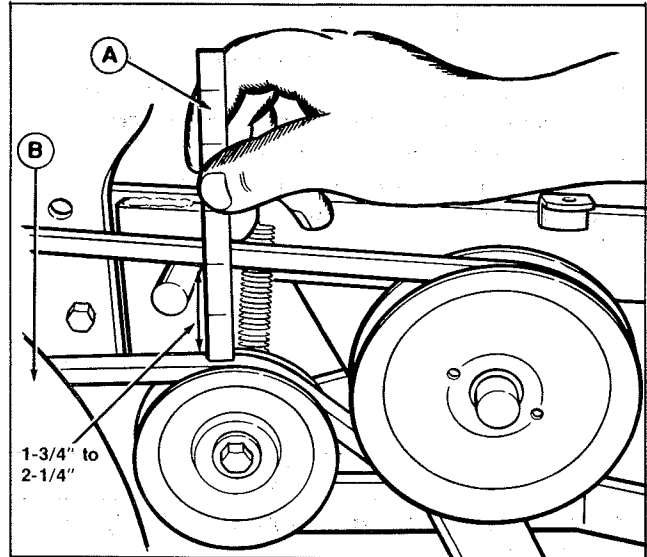

Figure 12. Belt Adjustment Measurement

- A. Ruler
- B. Left-Rear Tire

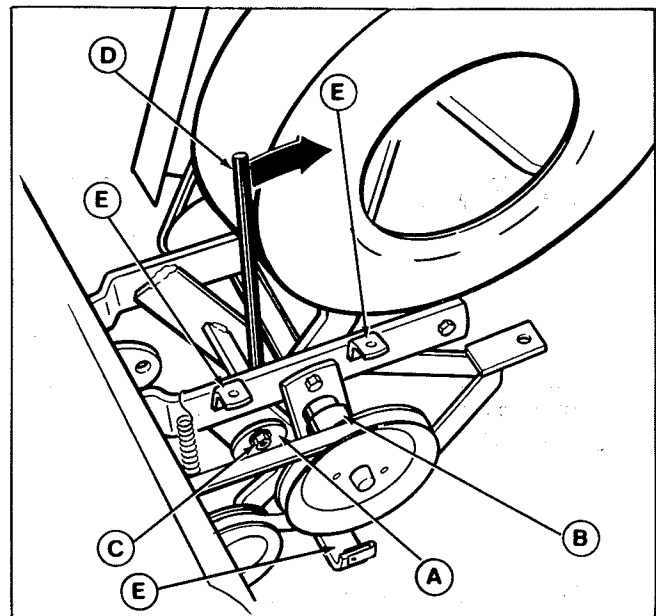

Figure 13. Moving Cross Shaft Back

- A. Eccentric Washer
- B. Cross Shaft
- C. Nut
- D. Crowbar
- E. Shield Brackets

Assembly

CONTENT OF SECTION

The vacuum collector may be received partially assembled. Procedures necessary to complete the assembly of the vacuum collector are provided in this section.

ASSEMBLY OF THE VACUUM COLLECTOR

1. For tractors without a rear lift kit installed on the tractor, a support shaft and two collars are provided for installing the vacuum collector on the tractor. (On tractor with a rear lift kit installed, proceed to step 2.) On tractors without a rear lift kit, place the two set collars provided on the support shaft, the larger collar with a lip going on the left side with the lip facing outward. Position the support shaft in the tractor support arms on the tractor so that the lip of the larger collar fits inside the left support and the end of the shaft is flush with the outside edge of the right support arm. Tighten the set collars so that there is no play from side to side in the support shaft. (See figure 14.)

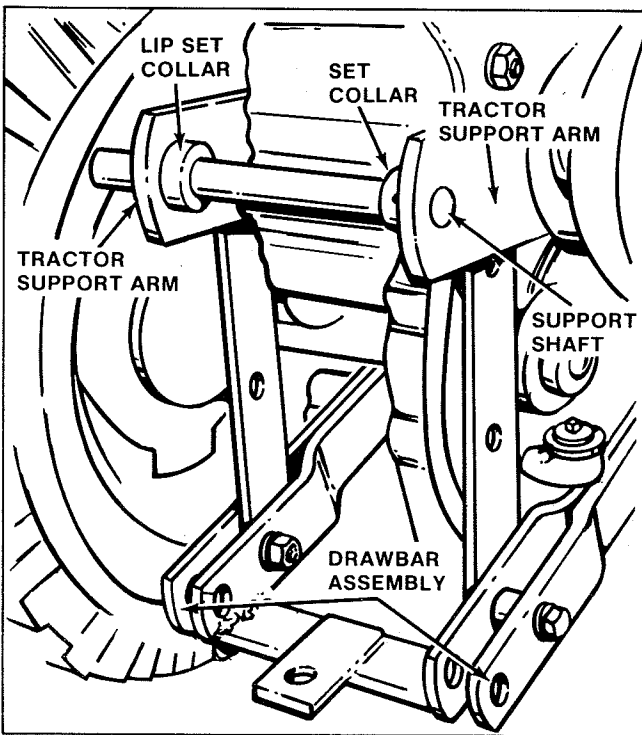

Figure 14. Installing Support Shaft

2. Remove the deflector from the mower, keeping the carriage bolts in place in the mower housing. Place the spacer provided with the vacuum collector adaptor on the front carriage bolt, then

reinstall the flat washer, lockwasher and nut that were on the bolt. Tighten the nut on the bolt. (See figure 15.)

3. Replace the lockwasher and nut on the top carriage bolt, and tighten the nut to the mower housing. The vacuum collector adaptor will fit over this bolt, with the wing nut holding it down.

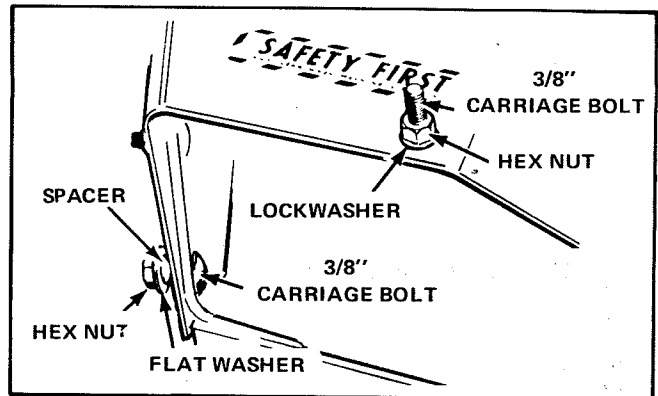

Figure 15. Preparing Mower Deck

4. The rear, top bolt used for the deflector is not used for the adaptor. Store in a safe place to avoid loss.
5. Place the correct vacuum collector adaptor on the mower housing as shown in figure 16. The front slot fits over the spacer just installed, and the top hole fits over the carriage bolt on the top of the mower housing. Place the wing nut on the top carriage bolt and tighten it.

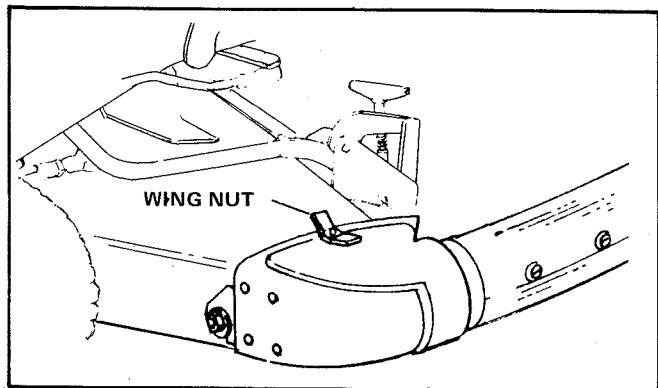

Figure 16. Installing Adaptor

6. Assemble the inlet tube with the phillips head screws, flat washers, lockwashers and nuts provided. Place a flat washer on each screw, and insert the screws from the inside of the tube, placing a flat washer, lockwasher, and nut on each screw on the outside of the tube. (See figure 17.)

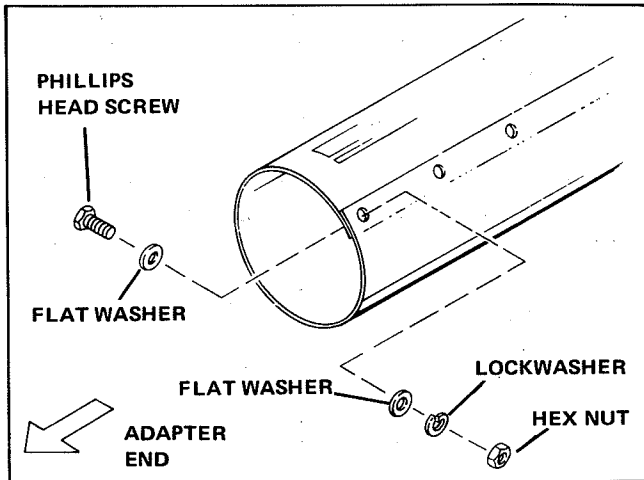

Figure 17. Assembling Inlet Tube

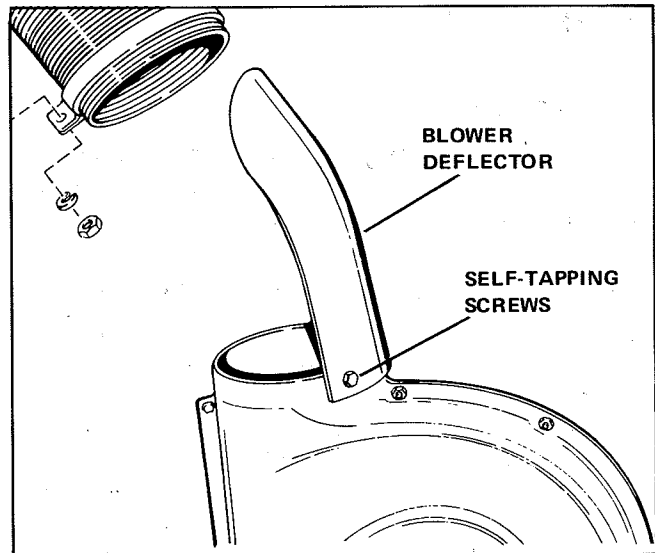

Figure 19. Assembling Deflector

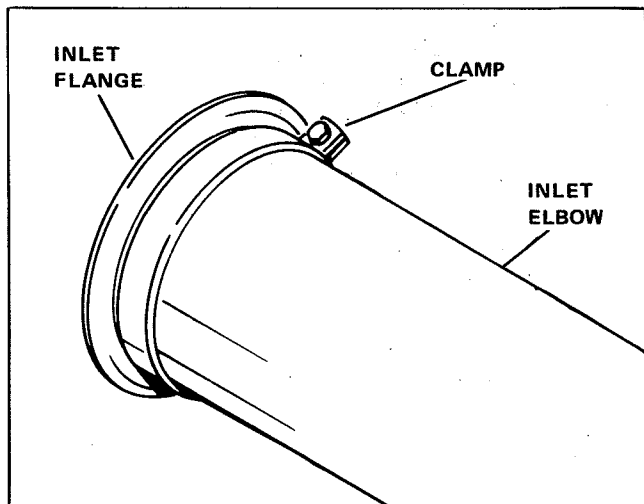

Figure 18. Assembling Inlet Elbow

7. Insert the inlet flange into the long end of the inlet elbow, and hold the flange tight in the inlet elbow with a clamp and screw. (See figure 18.)
8. Attach the blower deflector to the outside of the blower housing with two self-tapping screws. (See figure 19.)
9. The shield and three wing screws can be installed after the vacuum collector has been installed on tractor (see Installation). The shield is shown in figure 5.

Hoses	Wire Reinforced Rubber Coated Fabric
Fan	Welded Steel Fan Assembly. Rotating on a Factory Lubricated and sealed high speed double row ball bearing.
Discharge	Accepts mower discharge from left hand side and discharges upward and rearward into dump cart cover.
Power Drive	From tractor bevel gearbox (PTO)
Overall Dimensions	Width 10-3/4 Inches (273 mm)
	Length 21-3/4 Inches (552.5 mm)
	Height 27-1/8 Inches (689 mm)

SPECIFICATIONS SUBJECT TO CHANGE WITHOUT NOTICE

